



AZD vehicles offer up to 40% fuel economy improvement, save up to 30% in maintenance costs and reduce greenhouse gas emissions.

AZD Balance™ Hybrid Electric Ford E-450 Cutaway and Strip Chassis

Azure Dynamics (AZD) develops hybrid electric and electric drive technology for commercial trucks and shuttle buses. Working in collaboration with Ford Motor Company, AZD has developed a parallel hybrid electric drive system for Ford's E-450 Cutaway and Strip Chassis trucks. The parallel hybrid drive system manages the conventional 5.4 litre Triton gas engine and the 5-speed automatic TorqShift transmission to produce a cleaner, more fuel efficient vehicle for your business needs. The hybrid features electric-launch assist, engine-off at idle and regenerative braking which combine to improve fuel economy and reduce greenhouse gas emissions.



AZD Balance™ Hybrid Electric Ford E-450 Cutaway and Strip Chassis

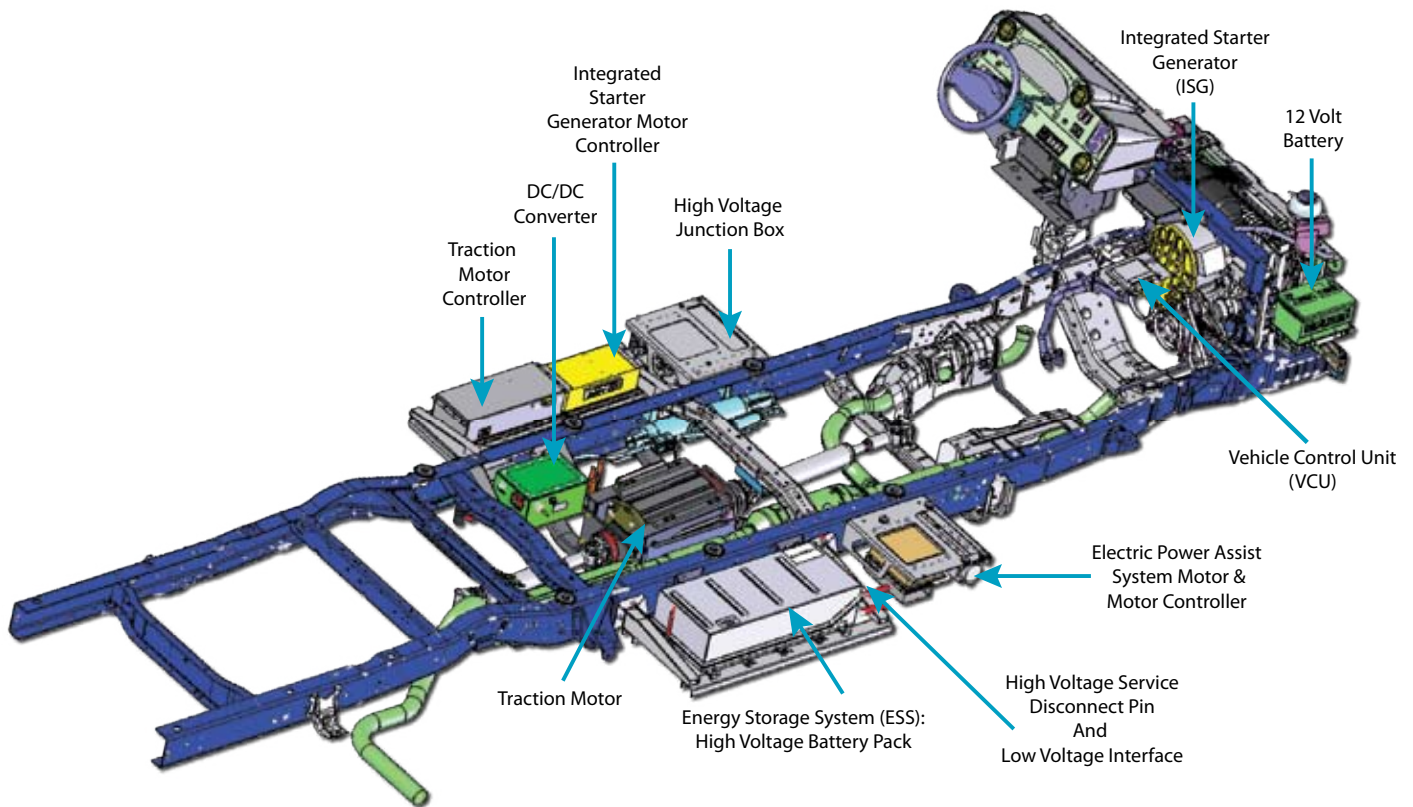

Parallel Hybrid Vehicles

AZD's Balance™ Hybrid Electric Ford E-450 offers you a clean alternative for your fleet needs today. Depending on your duty cycle you can experience up to 40 percent fuel economy improvement, up to 30 percent lower maintenance costs and a reduction in greenhouse gas emissions by up to 30%

AZD's Balance™ Hybrid Electric Ford E-450 can make a difference to your bottom line and your carbon footprint. Some specifications for you to consider:

- E-450 Stripped & Cutaway Chassis available
- GVWR up to 14,500 lbs
- 5.4L Gas engine with Torqshift automatic transmission
- 158 or 176 inch wheelbase
- Minimum body width requirement of 86 inches

An AZD Balance™ Hybrid Electric Ford E-350 Stripped & Cutaway Chassis will be available in fall of 2009. In addition, an AZD Balance™ Hybrid Electric E-450 shuttle bus will be available in the spring of 2009.



Driving a World of difference.®

AZD
AZURE DYNAMICS
part of the solution™

For further information on how we can green your fleet contact **Mike Byers** Director, Fleet Sales
248.298.2403 Ext. 1204 mbyers@azuredynamics.com or call toll free 877.932.9009